

<b>Incident Name</b> July 2023 Pensacola Beach Air Show		<b>Operational Period</b>	<b>Date From</b> 07/06/2023 <b>Time From</b> 07:00:00	<b>Date To</b> 07/06/2023 <b>Time To</b> 19:00:00
<b>Approved by</b>	<b>Name</b> Kevin Riley	<b>Title</b> Planning Section Chief	<b>Date/Time Approved</b> 07/06/2023 07:00:00	
	Scottlin Williams	EM Coordinator	07/06/2023 07:00:00	
	Travis Tompkins	Incident Commander	07/06/2023 07:00:00	

# Incident Action Plan



Pensacola Beach Blue Angels Air Show July 6, 2023

<b>Prepared by</b>	<b>Name</b> Scottlin Williams	<b>Position/Title</b> EM Coordinator
<b>Signature</b> _____		<b>Date/Time</b> 06/27/2023 15:06:30



# Incident Objectives (ICS 202)

<b>Incident Name</b> July 2023 Pensacola Beach Air Show	<b>Operational Period</b>	<b>Date From</b> 07/06/2023 <b>Time From</b> 07:00:00	<b>Date To</b> 07/06/2023 <b>Time To</b> 19:00:00
<b>Objective(s)</b>			
<ol style="list-style-type: none"> <li>1 Identify and mitigate threats to the safety of responders for the duration of the event.</li> <li>2 Utilize pre-deployed responder assets to provide a safe, rapid response and secure environment for all air show attendees throughout the duration of the event.</li> <li>3 Support and manage the significant traffic on Pensacola Beach with safe and efficient entry and exit strategies and traffic control plans for the duration of the event.</li> <li>4 Monitor all potential hazards and threats, responding with appropriate timely actions or mitigating strategies for the duration of the event.</li> </ol>			
<b>Operational Period Command Emphasis</b>			
The Pensacola Beach Blue Angels Air Show will be a three day event. Scheduled to be prep/setup starting Wednesday, limited rehearsals occurring on Thursday, full dress rehearsals on Friday, with the primary air show launching Saturday. Sunday will be a rain date for the Saturday Show.			
<b>General Situational Awareness (Weather, General Safety Message)</b>			
<p>1. Typical Pensacola Beach summer weather is to be expected with high humidity, heat, and the threat of sunburn on unprotected skin probable. Use sunscreen and shade to protect yourself and force hydration. Make it a personal mission to protect yourself from heat stress or exhaustion.</p> <p>-Expect high temperatures in the lower 90s, with feels like temperatures in the triple digits (not quite at the heat advisory threshold). Winds will be out of the northwest at 5-10 mph, becoming southwest in the afternoon. There is a 80% chance for scattered storms. A total washout is not expected. If there is thunder and/or lightning, everyone should seek shelter. An isolated strong storm is possible, but chances are low. The main threat would be frequent lightning and locally heavy rain, but gusty winds cannot be ruled out.</p> <p>-Remember heat safety tips: Stay hydrated with water, take frequent breaks in the shade (or A/C, if possible), wear sunscreen, know the signs of heat related illnesses, etc.</p> <p>2. Use extreme caution when operating vehicles or equipment. Large, distracted crowds of people are expected and they will not be paying attention to you or the vehicle you operate. Utilize proper vehicle operation procedures and utilize backbrakes when moving any equipment or vehicles in reverse. 3. Keep your head on a swivel and stay engaged! Your safety comes first. Situational awareness is the key to a safe and rewarding tour making this the safest and best air show ever.</p>			
<b>Site Safety Plan Required?</b>			
Yes <input type="checkbox"/> No <input checked="" type="checkbox"/>			
<b>Approved Site Safety Plan(s) Located At:</b>			
<b>Incident Action Plan (the items checked below are included in this Incident Action Plan)</b>			
<input checked="" type="checkbox"/> ICS 200	<input checked="" type="checkbox"/> ICS 205A	<input type="checkbox"/> ICS 211p-OS	
<input checked="" type="checkbox"/> ICS 201	<input checked="" type="checkbox"/> ICS 206	<input type="checkbox"/> ICS 215	
<input checked="" type="checkbox"/> ICS 202	<input type="checkbox"/> ICS 207	<input type="checkbox"/> ICS 215A	
<input checked="" type="checkbox"/> ICS 203	<input checked="" type="checkbox"/> ICS 208	<input type="checkbox"/> ICS 220	
<input checked="" type="checkbox"/> ICS 204	<input type="checkbox"/> ICS 209	<input checked="" type="checkbox"/> ICS 230	
<input checked="" type="checkbox"/> ICS 205	<input type="checkbox"/> ICS 211e-OS	<input type="checkbox"/> ICS 232	
		<input type="checkbox"/> ICS 233	
<b>Prepared by</b>			
<b>Name</b> Scottlin Williams		<b>Position/Title</b> EM Coordinator	
<b>Signature</b> _____		<b>Date/Time</b> 07/06/2023 06:55:57	

# Organization Assignment List (ICS 203)

<b>Incident Name</b> July 2023 Pensacola Beach Air Show		<b>Operational Period</b>	<b>Date From</b> 07/06/2023 <b>Time From</b> 07:00:00	<b>Date To</b> 07/06/2023 <b>Time To</b> 19:00:00
<b>Incident Commander(s) and Command Staff</b>		<b>Operations Section</b>		
<b>IC/UCs</b>	Travis Tompkins	<b>Chief</b>	Tim Trowbridge	
<b>Deputy</b>	Chris Holloman	<b>Deputy</b>		
<b>Safety Officer</b>	Joel Richardson	<b>Staging Area</b>		
<b>Public Info. Officer</b>	Andrea "Andie" Gibson	<b>Comms Branch</b>		
<b>Liaison Officer</b>		<b>Branch Director</b>	Andrew Hamilton	
<b>Agency/Organization Representatives</b>		<b>Deputy</b>	Christy Buscaino	
<b>Agency/Organization</b>	<b>Name</b>	<b>Communications Branch</b>	Andrew Hamilton	
<b>Planning Section</b>		<b>Fire Branch</b>		
<b>Chief</b>	Kevin Riley	<b>Branch Director</b>	Paul Williams	
<b>Deputy</b>		<b>Deputy</b>	Greg Campanella	
<b>Resources Unit</b>		<b>Fire Branch</b>	Paul Williams	
<b>Situation Unit</b>		<b>FWC Branch</b>		
<b>Documentation Unit</b>		<b>Branch Director</b>	Douglas Berryman	
<b>Demobilization Unit</b>		<b>Deputy</b>	Britton Corbin	
<b>Technical Specialists</b>		<b>FWC Branch</b>	Doug Berryman	
<b>Logistics Section</b>		<b>LE Branch</b>		
<b>Chief</b>		<b>Branch Director</b>	James Barnes	
<b>Deputy</b>		<b>Deputy</b>	Jacob Holloway	
<b>Support Branch</b>		<b>Law Enforcement Branch</b>	James Barnes	
<b>Director</b>		<b>Life Guards</b>		
<b>Supply Unit</b>		<b>Branch Director</b>	Dave Greenwood	
<b>Facilities Unit</b>		<b>Deputy</b>	(Alex) A.J. Johnson	
<b>Ground Support Unit</b>		<b>Life Guards</b>	A.J. (Alex) Johnson	
<b>Service Branch</b>		<b>Med Branch</b>		
<b>Director</b>		<b>Branch Director</b>	Derrick Elmer	
<b>Communications Unit</b>		<b>Deputy</b>	Ian Mays	
<b>Medical Unit</b>		<b>Medical Branch</b>	Derrick Elmer	
<b>Food Unit</b>		<b>Finance/Administration Section</b>		
		<b>Chief</b>		
		<b>Deputy</b>		
		<b>Time Unit</b>		
		<b>Procurement Unit</b>		
		<b>Comp/Claims Unit</b>		
		<b>Cost Unit</b>		
<b>Prepared by</b>				
<b>Name</b> Scottlin Williams		<b>Position/Title</b> EM Coordinator		
<b>Signature</b> _____		<b>Date/Time</b> 07/05/2023 15:28:01		

# Assignment List (ICS 204)

<b>Incident Name</b> July 2023 Pensacola Beach Air Show		<b>Operational Period</b>		<b>Date From</b> 07/06/2023 <b>Time From</b> 07:00:00	<b>Date To</b> 07/06/2023 <b>Time To</b> 19:00:00
<b>Branch</b> Comms Branch		<b>Division/Group</b> Communications Branch		<b>Staging Area</b>	
<b>Operations Personnel</b>		<b>Name</b>		<b>Contact-Number(s)</b>	
<b>Operations Section Chief:</b>		Tim Trowbridge			
<b>Branch Director:</b>		Andrew Hamilton		850-377-5333	
<b>Division/Group Supervisor:</b>		Andrew Hamilton		850-377-5333	
<b>Resources Assigned</b>					
<b>Resource Identifier</b>	<b>Leader</b>	<b># of Persons</b>	<b>Contact (e.g., phone, pager, radio frequency, etc.)</b>	<b>Reporting Location, Special Equipment and Supplies, Remarks, Notes, Information</b>	
Comms 1	Andrew Hamilton	5	850-377-5333		
<b>Work Assignments</b>					
Dispatch and coordination of emergency calls within the airshow footprint. The ECC will build 9-1-1 request into CAD and airshow Comms personnel will assign, direct, track and coordinate emergency response personnel.					
<b>Special Instructions</b>					
<b>Communications (radio and/or phone contact numbers needed for this assignment)</b>					
<b>Name</b>		<b>Function</b>		<b>Primary Contact (indicate cell, pager, or radio)</b>	
Andrew Hamilton		Comms Lead		850-377-5333	
Christy Buscaino		Comms Lead		850-202-6799	
<b>Prepared by</b>					
<b>Name</b> Hamilton			<b>Position/Title</b> Communications Chief		
<b>Signature</b> _____			<b>Date/Time</b> 06/29/2023 16:46:40		

# Assignment List (ICS 204)

<b>Incident Name</b> July 2023 Pensacola Beach Air Show		<b>Operational Period</b>		<b>Date From</b> 07/06/2023 <b>Time From</b> 07:00:00	<b>Date To</b> 07/06/2023 <b>Time To</b> 19:00:00
<b>Branch</b> Fire Branch		<b>Division/Group</b> Fire Branch		<b>Staging Area</b>	
<b>Operations Personnel</b>		<b>Name</b>		<b>Contact-Number(s)</b>	
<b>Operations Section Chief:</b>		Tim Trowbridge			
<b>Branch Director:</b>		Paul Williams		850-377-1039	
<b>Division/Group Supervisor:</b>		Paul Williams		850-393-4291	
<b>Resources Assigned</b>					
Resource Identifier	Leader	# of Persons	Contact (e.g., phone, pager, radio frequency, etc.)	Reporting Location, Special Equipment and Supplies, Remarks, Notes, Information	
Ladder 13	Averill, Scott (Captain)	4	850-375-5088	Station 13	
Engine 13	Diamond, Brian (Lieutenant)	4	850-393-0666	Casino Beach ALS company	
Tower 7	Forrester, Ian (Lieutenant)	4	Radio	Santa Rosa Dunes (Ft. Pickens Rd)	
ATV 15	Beachy, AJ (Assistant District Chief)	2	Radio	Casino Beach & Quietwater Beach	
Brush 14	McCleary, Paul (Acting Officer)	2	Radio	ECSO Sub-station	
Navy TAU 655	BC Cullan	2	Radio	ECSO Sub-station	
1328 with PWC	Rowe, Josh (Lieutenant)	2	Radio	Station 13	
1329 with PWC	Chapman, Keith (Lieutenant)	2	Radio	Casino Beach	
<b>Work Assignments</b>					
Fire/Rescue resources are strategically staged to respond to incidents as dispatched.					
<b>Special Instructions</b>					
<b>Communications (radio and/or phone contact numbers needed for this assignment)</b>					
<b>Name</b>		<b>Function</b>		<b>Primary Contact (indicate cell, pager, or radio)</b>	
<b>Prepared by</b>					
<b>Name</b> Paul Williams		<b>Position/Title</b> Deputy Fire Chief			
<b>Signature</b> _____		<b>Date/Time</b> 07/06/2023 06:52:07			

# Assignment List (ICS 204)

<b>Incident Name</b> July 2023 Pensacola Beach Air Show		<b>Operational Period</b>		<b>Date From</b> 07/06/2023 <b>Time From</b> 07:00:00	<b>Date To</b> 07/06/2023 <b>Time To</b> 19:00:00
<b>Branch</b> FWC Branch		<b>Division/Group</b> FWC Branch		<b>Staging Area</b>	
<b>Operations Personnel</b>		<b>Name</b>		<b>Contact-Number(s)</b>	
<b>Operations Section Chief:</b>		Tim Trowbridge			
<b>Branch Director:</b>		Douglas Berryman		850-382-3898	
<b>Division/Group Supervisor:</b>		Doug Berryman		850-382-3898	
<b>Resources Assigned</b>					
<b>Resource Identifier</b>	<b>Leader</b>	<b># of Persons</b>	<b>Contact (e.g., phone, pager, radio frequency, etc.)</b>	<b>Reporting Location, Special Equipment and Supplies, Remarks, Notes, Information</b>	
FWC Officers	Doug Berryman	7	850-382-3898		
<b>Work Assignments</b>					
Thursday July 06, 2023:					
<b>Officer:</b>	<b>Vessel:</b>	<b>Shift:</b>	<b>On Scene Times:</b>	<b>Zone:</b>	
Off Heath Nichols	NA	0800-1800	0900-1700 (Set-up)	BG Marina	
Lt. Corbin	NA	0700-1900	0800-1900	1-4	
Lt. Berryman	NA	0700-1900	1100-1700	1-4	
Jimmie McHenry	20' Pathfinder	0900-1700	1000-1600	1	
Sean Long	24' Young	0900-1700	1000-1600	2	
Chris Petty	25 Contender (Lugg)	0900-1700	1000-1600	3	
Billy Wilkenson	23 Pathfinder	0900-1700	1000-1600	4	
<b>Special Instructions</b>					
See attached FWC Operational Plan					
<b>Communications (radio and/or phone contact numbers needed for this assignment)</b>					
<b>Name</b>		<b>Function</b>		<b>Primary Contact (indicate cell, pager, or radio)</b>	
<b>Prepared by</b>					
<b>Name</b>			<b>Position/Title</b>		
<b>Signature</b> _____			<b>Date/Time</b> 07/05/2023 15:29:24		

# Assignment List (ICS 204)

<b>Incident Name</b> July 2023 Pensacola Beach Air Show		<b>Operational Period</b>		<b>Date From</b> 07/06/2023 <b>Time From</b> 07:00:00	<b>Date To</b> 07/06/2023 <b>Time To</b> 19:00:00
<b>Branch</b> LE Branch		<b>Division/Group</b> Law Enforcement Branch		<b>Staging Area</b>	
<b>Operations Personnel</b>		<b>Name</b>		<b>Contact-Number(s)</b>	
<b>Operations Section Chief:</b>		Tim Trowbridge			
<b>Branch Director:</b>		James Barnes		850-529-2496	
<b>Division/Group Supervisor:</b>		James Barnes		850-529-2496	
<b>Resources Assigned</b>					
Resource Identifier	Leader	# of Persons	Contact (e.g., phone, pager, radio frequency, etc.)	Reporting Location, Special Equipment and Supplies, Remarks, Notes, Information	
ECSO Deputies	James Barnes	10	850-786-7097	Sheriff's Substation	
Bomb Squad	Chris Newman	2	850-417-6680	CP, ECSO Radio	
FHP WMD Team	Artez Lester	12	850-527-1435	CP, ECSO Radio	
FBI	Alex Chan	2	850-461-2862	Command Post	
FDLE	Heather Kinnard	2	850-490-1705	Command Post	
Pensacola PD	Jamie Briarton	1	850-698-0851	Will be available via PX if additional assistance is needed beyond normal day to day requests. Dispatch PX#850-595-1214.	
Gulf Breeze PD	Stef Neff	1	850-686-6642	Will be available via PX if assistance is needed beyond day to day requests.	
National Parks Police	Dede Mladucky	4	850-916-5672	Will be patrolling National Parks areas.	
<b>Work Assignments</b>					
<p>ECSO will provide law enforcement presence/patrol for airshow event and surrounding areas.  Bomb Squad will provide assistance if a suspicious package or bomb incident occurs.  FHP WMD Team will monitor for radioactive devices and provide assistance if a WMD incident occurs.  FBI members will act as a federal liaison and provided intel of possible threats.  FDLE members will act as a state law enforcement liaison and assist with intel of possible threats.  PPD will be available for assistance with traffic at 9th and Gregory.  GPD will be available for assistance with traffic if needed.  National Parks will be patrolling the National Park lands and will provide assistance as needed.</p>					
<b>Special Instructions</b>					
ECSO rep in Command Post will have a cache of radios to lend to agencies who will need direct comms to ECSO if needed.					
<b>Communications (radio and/or phone contact numbers needed for this assignment)</b>					
<b>Name</b>		<b>Function</b>		<b>Primary Contact (indicate cell, pager, or radio)</b>	
<b>Prepared by</b>					
<b>Name</b> Jacob Holloway			<b>Position/Title</b>		
<b>Signature</b> _____			<b>Date/Time</b> 07/05/2023 08:01:17		



# Assignment List (ICS 204)

<b>Incident Name</b> July 2023 Pensacola Beach Air Show		<b>Operational Period</b>		<b>Date From</b> 07/06/2023 <b>Time From</b> 07:00:00	<b>Date To</b> 07/06/2023 <b>Time To</b> 19:00:00
<b>Branch</b> Life Guards		<b>Division/Group</b> Life Guards		<b>Staging Area</b>	
<b>Operations Personnel</b>		<b>Name</b>		<b>Contact-Number(s)</b>	
<b>Operations Section Chief:</b>		Tim Trowbridge			
<b>Branch Director:</b>		Dave Greenwood		850-554-4302	
<b>Division/Group Supervisor:</b>		A.J. (Alex) Johnson		850-503-1799	
<b>Resources Assigned</b>					
<b>Resource Identifier</b>	<b>Leader</b>	<b># of Persons</b>	<b>Contact (e.g., phone, pager, radio frequency, etc.)</b>	<b>Reporting Location, Special Equipment and Supplies, Remarks, Notes, Information</b>	
Lifeguards	A.J. (Alex) Johnson	25	(850) 503-1799 / UHF 466.300	Lifeguard Towers and Patrols	
<b>Work Assignments</b>					
Lifeguards will maintain beach and water surveillance. Lifeguards will clear the water and keep water clear of the public in the airshow box during airshow performances. Lifeguards will notify public of no drones or kites in the airshow box. Lifeguards will perform water rescues as needed, assist with first aid, patient extraction from the beach, and helping to reunite lost children. Lifeguards will perform other Public Safety functions or emergency response on the beach as needed.					
<b>Special Instructions</b>					
Lifeguards will report at 09:30, and barring special circumstances will depart at 18:30 hours.					
<b>Communications (radio and/or phone contact numbers needed for this assignment)</b>					
<b>Name</b>	<b>Function</b>	<b>Primary Contact (indicate cell, pager, or radio)</b>			
Dave Greenwood	Branch Director	850-443-4302 - UHF 466.300			
A.J. (Alex) Johnson	Division Supervisor	850-503-1799 - UHF 466.300			
Senior Lifeguard	Leader	850-554-4301 - UHF 466.300			
<b>Prepared by</b>					
<b>Name</b> A.J. (Alex) Johnson		<b>Position/Title</b> Life Guard Supervisor			
<b>Signature</b> _____		<b>Date/Time</b> 07/05/2023 15:02:27			

# Assignment List (ICS 204)

<b>Incident Name</b> July 2023 Pensacola Beach Air Show		<b>Operational Period</b>		<b>Date From</b> 07/06/2023 <b>Time From</b> 07:00:00		<b>Date To</b> 07/06/2023 <b>Time To</b> 19:00:00	
<b>Branch</b> Med Branch		<b>Division/Group</b> Medical Branch		<b>Staging Area</b>			
<b>Operations Personnel</b>		<b>Name</b>		<b>Contact-Number(s)</b>			
<b>Operations Section Chief:</b>		Tim Trowbridge					
<b>Branch Director:</b>		Derrick Elmer		850-572-0385			
<b>Division/Group Supervisor:</b>		Derrick Elmer		850-572-0385			
<b>Resources Assigned</b>							
Resource Identifier	Leader	# of Persons	Contact (e.g., phone, pager, radio frequency, etc.)	Reporting Location, Special Equipment and Supplies, Remarks, Notes, Information			
ECEMS Medic 91	Daniel Miller	2	Tac-3	ECEMS staging Casino Beach			
ECEMS Medic 92	Jordan Lance	2	Tac-3	ECEMS staging Casino Beach			
ECEMS Medic 93	Kimberly Ard	2	Tac-3	ECEMS staging Casino Beach			
ECEMS UTV-1	William Young	2	Tac-3	ECEMS staging Casino Beach			
ECEMS UTV-2	Nicholas Watley	2	Tac-3	ECEMS staging Casino Beach			
ECEMS Golf Cart	Katelyn Hallman	2	Tac-3	Quietwater Beach/SRIA			
ECEMS Medical Tent	Tasha Boros	7	Tac-3	patient management area, ECEMS staging Casino Beach			
<b>Work Assignments</b>							
Medic and UTV units will be staged at Casino Beach. ECEMS Golf Cart to be staged at Quietwater Beach/SRIA (to be used on hard surfaces only).							
<b>Special Instructions</b>							
Piers to be used for waterside pickup of medical patients at the following locations: Northside of the "T Pier behind the Quietwater Beach shell. Fuel station at Sabine Marina 655 Pensacola Beach Blvd. on Little Sabine.							
<b>Communications (radio and/or phone contact numbers needed for this assignment)</b>							
Name		Function		Primary Contact (indicate cell, pager, or radio)			
ECEMS Operations				Escambia County Tac-3			
<b>Prepared by</b>							
<b>Name</b> Derrick Elmer				<b>Position/Title</b> Branch Director			
<b>Signature</b> _____				<b>Date/Time</b> 06/30/2023 08:36:30			

# Incident Radio Communications Plan (ICS 205)

<b>Incident Name</b> July 2023 Pensacola Beach Air Show	<b>Operational Period</b>	<b>Date From</b> 07/06/2023 <b>Time From</b> 07:00:00	<b>Date To</b> 07/06/2023 <b>Time To</b> 19:00:00
--	---------------------------	--	--

Basic Radio Channel Use									
Zone Grp.	Ch #	Function	Channel Name/ Trunked Radio System Talkgroup	Assignment	Rx Freq N or W	RX Tone/NAC	TX Freq N or W	TX Tone/NAC	Mode (A, D, or M)
	12	TACTICAL	VHF23A	USCG/FWC	157.150		157.150		A
<b>Remarks</b> MARINE SEARCH AND RESCUE									
	11	TACTICAL	VHF81A	FWC OPS	157.075		157.075		A
<b>Remarks</b> FWC PRIMARY - ALL VESSELS EQUIPED SHOULD MONITOR FOR EMERGENCY MESSAGES.									
	10	TACTICAL	ESCAMBIA TAC 5	ECFR/LZ OPERATIONS	465.6250	1AF	460.6250	1AF	D
<b>Remarks</b> TALK AROUND ONLY BETWEEN HELO AND LZ CREW									
	9	DISPATCH/TA CTICAL	UTAC 41	JOINT MARINE OPERATIONS	458.5625		143.4625		A
<b>Remarks</b>									
	8	MARINE DISTRESS/SA FETY	USCG 16	USCG	156.8000	5A	156.8000	5A	A
<b>Remarks</b>									
	7	TACTICAL	USCG 83A	USCG/FWC	157.1750		157.1750		A
<b>Remarks</b>									
	6	TACTICAL	FWC-SLERS DETAIL "B"	FWC TALK AROUND					D
<b>Remarks</b>									
	5	DISPATCH/TA CTICAL	FWC-SLERS DETAIL "A"	COMMS W/TALLAHAS SEE REGIONAL (TRCC)					D
<b>Remarks</b>									
	4	DISPATCH/TA CTICAL	ESCAMBIA TAC 6	FIRE	458.9250	9D6	453.9250	9D6	D
<b>Remarks</b>									
	3	DISPATCH/TA CTICAL	ESCAMBIA TAC 3	EMS	465.6000	11	460.6000	11	D
<b>Remarks</b>									
	2	DISPATCH/TA CTICAL	SO BEACH	SHERIFFS OFFICE	465.2000	E47	460.2000	E47	D
<b>Remarks</b>									
	1	TACTICAL	ESCAMBIA INTEROPS	LIFEGUARDS	460.0250	DE7	460.0250	DE7	D
<b>Remarks</b>									

**Special Instructions**

SOME CHANNEL PATCHING AVAILABLE TROUGH ESCAMBIA ECC CONSOLE

USE PLAIN LANGUAGE ALL CHANNELS

PRACTICE GOOD RADIO DISCIPLINE - CLOSE THE COMMUNICATION LOOP. DONT ASSUME YOU'VE BEEN HEARD.

LIMIT RADIO TRAFFIC. (ABC = ACCURATE, BRIEF, CLEAR)

USE TALK AROUND FOR LOW PRIORITY TRAFFIC

**Prepared by**

**Name** Andrew Hamilton **Position/Title** Comms Branch Director

**Signature** \_\_\_\_\_ **Date/Time** 07/05/2023 15:36:18

# Communications List (ICS 205A)

<b>Incident Name</b> July 2023 Pensacola Beach Air Show	<b>Operational Period</b>	<b>Date From</b> 07/06/2023 <b>Time From</b> 07:00:00	<b>Date To</b> 07/06/2023 <b>Time To</b> 19:00:00
<b>Basic Local Communications Information</b>			
<b>Incident Assigned Position</b>	<b>Name (Alphabetized)</b>	<b>Method(s) of Contact (phone, pager, cell, etc.)</b>	
Life Guard Deputy	A.J. (Alex) Johnson	850-503-1799	
Public Information Officer	Andrea "Andie" Gibson	850-530-3501	
Comms Branch Director	Andrew Hamilton	850-377-5333	
Marine Branch Deputy	Britton Corbin	850-305-7559	
Deputy Incident Commander	Chris Holloman	850-554-4052	
Comms Branch Deputy I	Christy Buscaino	850-202-6799	
Logistics Section Chief	Cooper Saunders	850-393-4961	
Life Guard Director	Dave Greenwood	850-554-4302	
Med Branch Director	Derrick Elmer	850-572-0385	
Marine Branch Director	Douglas Berryman	850-382-3898	
Fire Branch Deputy; Fire/Marine Liaison	Greg Campanella	850-375-0370	
Med Branch Deputy	Ian Mays	850-393-2189	
LE Branch Deputy I	Jacob Holloway	850-786-7159	
LE Branch Director	James Barnes	850-529-2496	
Safety Officer	Joel Richardson	850-393-2220	
LE Branch Deputy II	Kevin Pachucki	850-341-9316	
Planning Section Chief	Kevin Riley	850-572-8506	
IT	Krista Rudder	850-281-2673	
Comms Branch Deputy II	Mark Carter	850-530-0566	
Chamber of Commerce President/Cooling Center POC	Meg Peltier	850-723-9858	
Battalion Chief	Norman Robinson	850-426-9980	
Fire Branch Director	Paul Williams	850-377-1039	
Emergency Management Liaison	Scottlin Williams	850-380-9244	
Operations Section Chief	Tim Trowbridge	850-490-9363	
Incident Commander	Travis Tompkins	850-393-3117	
<b>Prepared by</b>			
<b>Name</b> Scottlin Williams		<b>Position/Title</b> EM Coordinator	
<b>Signature</b> _____		<b>Date/Time</b> 07/05/2023 14:22:40	

# Medical Plan (ICS 206)

<b>Incident Name</b> July 2023 Pensacola Beach Air Show	<b>Operational Period</b>	<b>Date From</b> 07/06/2023 <b>Time From</b> 07:00:00	<b>Date To</b> 07/06/2023 <b>Time To</b> 19:00:00
--	---------------------------	--	--

Medical Aid Stations			
Name	Location	Contact Number(s)/Frequency	Paramedics on Site?
ECEMS Medical Tent	ECEMS Staging ECSO parking lot Casino Beach	Tasha Boros 850-860-2051	Yes

Transportation (indicate air or ground)				
Air/Ground	Ambulance Service	Location	Contact Number(s)/Frequency	Level of Service
Ground	Escambia County EMS	6575 N. W St. Pensacola, FL	850-471-6400	ALS
Ground	Lifeguard EMS	Avalon Blvd. Milton, FL.	850-777-4640	ALS
Air	Air Methods-Lifeflight	55 Service Center Rd. Pensacola, FL.	8507128354	ALS

Hospitals							
Hospital Name	Address, Latitude & Longitude if Helipad	Contact Number(s)/Frequency	Travel Time		Trauma Center	Burn Center	Helipad
			Air	Ground			
Baptist Gulf Breeze	1110 Gulf Breeze Pkwy, Gulf Breeze, FL.	850-934-2000		10-15 minutes	No	No	Yes
Ascension Sacred Heart	5151 N. 9th Ave. Pensacola, FL.	850-416-7000		35-45 minutes	Level II	No	Yes
Baptist Hospital	1000 W. Moreno St. Pensacola, FL.	850-434-4811		35-40 minutes	Level II	No	Yes
Perdido Bay ER	9400 W. Hwy 98	850-457-2200		35-45 minutes	No	No	Yes
Ascension Sacred Heart Free Standing ER	1501 W. Nine Mile Rd. Pensacola, FL.	850-746-4958		40-45 minutes	No	No	No
HCA Pine Forest Free Standing ER	3194 W. Nine Mile Rd. Pensacola, FL.	850-806-0101		40-45 minutes	No	No	No

Special Medical Emergency Procedures
<input type="checkbox"/> Check box if aviation assets are utilized for rescue. If assets are used, coordinate with Air Operations.

**Prepared by**

**Name** Derrick Elmer

**Position/Title** Branch Director

**Signature** \_\_\_\_\_

**Date/Time** 06/29/2023 12:41:43

# Safety Message/Plan (ICS 208)

<b>Incident Name</b> July 2023 Pensacola Beach Air Show	<b>Operational Period</b>	<b>Date From</b> 07/06/2023 <b>Time From</b> 07:00:00	<b>Date To</b> 07/06/2023 <b>Time To</b> 19:00:00
<b>Safety Message/Expanded Safety Message, Safety Plan, Site Safety Plan</b>			
Threats/Hazards			
<ul style="list-style-type: none"><li>• Large crowd control Ensure location of mass decon known for immediate CBRNE releases</li><li>• Traffic Control/parking Ensure ability to identify parking lots, rows, and locations for additional resources if needed</li><li>• Public Safety Ensure known locations of Aid tents, ECSO/LEO staging, and other pertinent information</li><li>• Water safety (watercraft and swimmers) All Workers must wear Life Vest when working in or around water. Use 3 points of contact when boarding/departing watercraft. No fire PPE should be worn on boats</li><li>• Severe weather threats Weather updates will be sent during operation meetings for timelines to be weather aware. Ensure a location for lightning evacuation for responders and public</li><li>• Medical needs for the public (heat exhaustion, dehydration, etc.) Ensure all responders have appropriate water and coolers for operational period. Sunscreen applied throughout operation period for exposure limitations</li><li>• Air accident Follow aircraft specific extrication plans for rescue of pilots/crew. See attached flight schedule to confirm aircraft timeline for which plan would be appropriate. No single suppression apparatus has enough extinguishment agent for crash, rescue crews when able, containment of fire as possible, and isolate area for crowd control</li><li>• Emergency Traffic- called on assigned channel when appropriate following established SOG's</li><li>• LZ operations PPE must be eye protection at minimum. Be aware of rotor wash on landing/leaving (secure loose items)</li></ul>			
<b>Site Safety Plan Required?</b>			
Yes <input type="checkbox"/> No <input checked="" type="checkbox"/>			
<b>Approved Site Safety Plan(s) Located At:</b>			
<b>Prepared by</b>			
<b>Name</b> Joel Richardson		<b>Position/Title</b> Safety Officer	
<b>Signature</b> _____		<b>Date/Time</b> 07/05/2023 20:22:42	

# Daily Meeting Schedule (ICS 230)

<b>Incident Name</b> July 2023 Pensacola Beach Air Show	<b>Operational Period</b>	<b>Date From</b> 07/06/2023 <b>Time From</b> 07:00:00	<b>Date To</b> 07/06/2023 <b>Time To</b> 19:00:00		
<b>Meeting Schedule</b>					
<b>Time</b>	<b>Meeting Name</b>	<b>Purpose</b>	<b>Attendees</b>	<b>Meeting Location</b>	<b>Meeting URL</b>
08:00:00	Fire/EMS Safety Briefing		Fire and EMS personnel	Escambia County Fire Rescue Station 13 - 901 Via De Luna, Gulf Breeze, FL 32561	
09:00:00	Operational Period Briefing		Command/General Staff, Branch Directors, and Leads for Supporting Agencies	THOR - Command Post	
15:30:00	Operational Period Debriefing		Command/General Staff, Branch Directors, and Leads of Supporting Agencies.	THOR - Command Post	
<b>Prepared by</b>					
<b>Name</b> Scottlin Williams			<b>Position/Title</b> EM Coordinator		
<b>Signature</b> _____			<b>Date/Time</b> 07/05/2023 14:05:51		







SCHEDULE FOR  
**PENSACOLA BEACH, FL**  
**PENSACOLA BEACH AIRSHOW**  
**8 JULY 2023**

**AIR SHOW POINTS OF CONTACT:**

AIR SHOW COORDINATOR: Robbie Schrock PHONE: N/A CELL: (850) 485-7589 EMAIL: robbie_schrock@sria-fla.com	FAA MONITOR: John Vaughan PHONE: N/A CELL: (205) 306-3968 EMAIL: john.vaughan@faa.gov
BLUE ANGEL LIAISON: Robbie Schrock PHONE: N/A CELL: (850) 485-7589 EMAIL: robbie_schrock@sria-fla.com	POLICE POC: Chief Richard Hawthorne PHONE: (850) 934-5121 CELL: (850) 232-9714 EMAIL: rhawthorne@gulfbreeze.fl.gov
MAINTENANCE POC: Kirk Troil PHONE: (850) 595-4719 CELL: (850) 281-9919 EMAIL: kptroil@myescambia.com	USN RECRUITER POC: N/A PHONE: N/A CELL: N/A EMAIL: N/A
PUBLICITY POC: Katie King PHONE: (850) 438-4015 CELL: (850) 723-6737 EMAIL: katie@ewbullock.com	USMC RECRUITER POC: N/A PHONE: N/A CELL: N/A EMAIL: N/A
SECURITY POC: James Barnes PHONE: (850) 932-9211 CELL: (850) 786-7097 EMAIL: jrbarnes@escambiaso.com	MEDICAL POC: Dave Greenwood PHONE: (850) 916-5232 CELL: (850) 554-4302 EMAIL: degreenwood@myescambia.com

<b>Start:</b> 1100 <b>BA Start:</b> 1400 <b>Sunset:</b> 1954
<b>Air Boss:</b> Paul Entrekin <b>Announcer:</b> Rob Williams
<b>Air Show Performers:</b> Kevin Coleman, Aaron Fitzgerald and Red Bull Air Force Jump Team, Veterans Flight, Bill Culberson, Redline, Skip Stewart

**SHOWSITE SPECIFICS**

**Brief Room:** Blue Angels Ready Room, 390 San Carlos Rd. Suite A, Pensacola, FL 32508  
 Phone: N/A

**Make-a-Wish POC:** N/A  
 Kids/Total: N/A  
 Cell: N/A

**SUNDAY, 2 JULY 2023 (Partly Cloudy, H: 93°, L: 78°)**  
 2030 Skeds/AOM

**MONDAY, 3 JULY 2023 (Partly Cloudy, H: 90°, L: 79°)**  
 0730 FA-18 Pilot Finalists – Pilot Strength Test #1 at NASC Track  
 0730 All other finalists – Navy Psychology Interviews, Pilot shop  
 0800 Finalists uniform measurements in Supply Office  
 1000 #7 meets with Pensacola Beach committee in Santa Rosa Island Authority  
 1300 FA-18 Pilot Finalists – Navy Psychology Interviews, Pilot shop  
 1800 Finalists’ dinner with 2024 team at The Fish House, 600 S Barracks St., Pensacola, FL 32502 (\$40/person)

**TUESDAY, 4 JULY 2023 (Scattered Thunderstorms, H: 91°, L: 78°)**  
 0530 Commence finalists’ interviews in Ready Room (Uniform – Khakis / Charlies) [1<sup>st</sup> Interview: 0600]  
 0545 Meet with Navy Psychologists in Ready Room  
 0545 Finalists arrive at squadron spaces and check-in with #2  
 0900 Finalists photos in front of jet in hangar  
 1055 Depart for finalists’ lunch at Cubi Point Bar, National Naval Aviation Museum (West Pac Room) (\$15/person) [Lunch: 1100]  
 1150 Resume finalist interviews  
 1800 Finalists dinner with 2023 team and spouses at Angelena’s Ristorante Italiano, 101 E. Intendencia St., Pensacola, FL 32502 (\$72/person)

**WEDNESDAY, 5 JULY 2023 (Scattered Thunderstorms, H: 91°, L: 77°)** (Airspace Waiver: 0730 – 1100) (TFR: 0730 – 1100)  
 0600 Finalists arrive at squadron spaces and complete Supply, Public Affairs, and Admin processing  
 0615 XO, MO, AMO, and Comm Cart personnel depart for Pensacola Beach (**Tan Polos / Blue Shorts**)  
 0625 Brief circles (with finalists)  
 0700 FA-18 Pilot Finalists – Pilot Strength Test #2 at Radford Gym  
 0700 #7 and #8 meet USCG helicopter pilot at NASP transient line POC: LT Rhea Phone: (903) 316-0170  
 0705 #7 and #8 depart NASP transient line for Pensacola Beach via USCG helicopter (on deck 0725)  
 0710 #1 – #4 walkdown for Pensacola Beach, FL circle maneuvers [OVHD: 0730]  
 0725 #7 and #8 return NASP transient line via USCG helicopter  
 0800 Breakfast with the Blues outreach – All interested at 3<sup>rd</sup> Floor Casino Beach Bar, 41 Ft. Pickens Rd., Pensacola Beach, FL  
 0810 #5 and #6 walkdown for Pensacola Beach, FL circle maneuvers [OVHD: 0830] [#5 Ride: #7]  
 0900 Diamond debrief circles (with finalists)  
 0925 Fat Albert launches for Pensacola Beach, FL circle maneuvers [OVHD: 0930]  
 1000 XO, MO, AMO, and Comm Cart personnel depart Pensacola Beach for airfield  
 1400 Beach Day with finalists at Casino Beach Bar and Grille; 41 Fort Pickens Rd., Gulf Breeze, FL 32561

**THURSDAY, 6 JULY 2023 (Scattered Thunderstorms, H: 90°, L: 76°)****(Airspace Waiver: 1300 – 1530) (TFR: 1300 – 1530)**

0800 7CC brief Key Influencer and Media Rider in Public Affairs  
 0900 #7 walkdown for Key Influencer Dr. Kimberly Thomas and Media Rider Mel McCrae flights (2) [0915, 1030]  
 1000 DH meeting  
 1120 [Boss], [#4, AZ2 Phibbs], [#5, PS1 Alvarez] and MC1 Deccio media availability in front of jets (1120 – 1140)  
 1220 #7, #8, XO, MO, AMO, DOC, SUPPO, and Comm Cart personnel depart for Coast Guard station (**Blue Polos / Tan Shorts**)  
 1230 #7, #8, XO, MO, AMO, DOC, SUPPO, and Comm Cart personnel depart Coast Guard station via boat for Peg Leg Pete's  
 1250 Brief  
 1310 #7, #8, XO, MO, AMO, DOC, SUPPO, and Comm Cart personnel depart Peg Leg Pete's for Pensacola Beach with police escort  
 1350 #1 – #6 walkdown for Pensacola Beach, FL practice flight demonstration [#4 Ride: LT Larissa Brandenburg]  
 1355 Fat Albert launches for Pensacola Beach, FL practice flight demonstration with approved riders [OVHD: 1400]  
 1355 LCDR Rickoff launches for Pensacola Beach Photo Platform with MC2 Cardona  
 1515 #7, #8, XO, MO, AMO, DOC, SUPPO, and Comm Cart personnel depart beach for Peg Leg Pete's with escort, then via boat to Coast Guard station  
 1615 Debrief  
 1730 Pick 2024 Blue Angel Officer Team Members

**FRIDAY, 7 JULY 2023 (Scattered Thunderstorms, H: 89°, L: 77°)****(Airspace Waiver: 1100 – 1700) (TFR: 1200 – 1600)**

0800 #8 Performers brief (VTC) POC: Robbie Schrock Phone: (850) 485-7589  
 1220 #7, #8, XO, Mini-XO, MO, DOC, and Comm Cart personnel depart for Coast Guard station (**Tan Polos/ Blue Shorts**)  
 1230 #7, #8, XO, Mini-XO, MO, DOC, and Comm Cart personnel depart Coast Guard station via boat for Peg Leg Pete's  
 1250 Brief  
 1310 #7, #8, XO, Mini-XO, MO, DOC, and Comm Cart personnel depart Peg Leg Pete's for Pensacola Beach with police escort  
 1350 #1 – #6 walkdown for Pensacola Beach, FL practice flight demonstration [OVHD: 1410] [#4 Ride: SUPPO]  
 1355 Fat Albert launches for Pensacola Beach, FL practice flight demonstration [OVHD: 1400]  
 1355 LCDR Rickoff launches for Pensacola Beach Photo Platform with MC2 Cardona (backup)  
 1515 #7, #8, XO, Mini-XO, MO, DOC, and Comm Cart personnel depart beach for Peg Leg Pete's with escort, then via boat to Coast Guard station  
 1615 Debrief

1900

**MANDATORY OFFICERS AND ENLISTED: Blue Angels Reception**

Scheduled: 1930-2130 (1900-1930: Reserved for BA &amp; Spouses)

Address: Hilton Pensacola Beach Gulf Front

12 Via de Luna, Pensacola Beach, FL 32561

Attire: Show Suits

Food: Hosted

Drinks: Hosted

Introductions: Yes

Presentations: Yes

Total Att: 550

Guest: Yes

Guest Attire: Business Casual

Host: Santa Rosa Island Authority

POC: Robbie Schrock

Phone: (850) 485-7589

Email: Robbie\_Schrock@sria-fla.com

Fundraiser for Host: No

Team Cost: None

Team Participation: None

Food/Drink Value: \$30.00

Cost of event for all attendees: \$20,000.00

Attendees: Community members, beach business owners, elected officials

**SATURDAY, 8 JULY 2023 (Scattered Thunderstorms, H: 89°, L: 78°)****(Airspace Waiver: 1100 – 1700) (TFR: 1200 – 1600)**

0800 XO Performers brief at Santa Rosa Island Authority, 1 Via de Luna Pensacola Beach, FL 32561  
 1000 All Officers arrive squadron spaces for finalist call-ins  
 1015 Finalist call-ins begin  
 1150 Finalist call-ins end  
 1220 #7, #8, Mini-XO, MO, AMO, DOC, SUPPO, and Comm Cart personnel depart for Coast Guard station (**Blue Polos / Tan Shorts**)  
 1230 #7, #8, Mini-XO, MO, AMO, DOC, SUPPO, and Comm Cart personnel depart Coast Guard station via boat for Peg Leg Pete's  
 1250 Brief  
 1310 #7, #8, Mini-XO, MO, AMO, DOC, SUPPO, and Comm Cart personnel depart Peg Leg Pete's for Pensacola Beach with police escort  
 1350 #1 – #6 walkdown for Pensacola Beach, FL flight demonstration [OVHD: 1410] **(30)**  
 1355 Fat Albert launches for Pensacola Beach, FL flight demonstration [OVHD: 1400]  
 1515 #7, #8, Mini-XO, MO, AMO, DOC, SUPPO, and Comm Cart personnel depart for Peg Leg Pete's with escort, then via boat to Coast Guard station  
 1615 Debrief

**SUNDAY, 9 JULY 2022 (Scattered Thunderstorms, H: 90°, L: 79°)****(Airspace Waiver: 1100 – 1700) (TFR: 1200 – 1600)****WEATHER BACK-UP DAY / NO FLIGHTS SCHEDULED / DAY OFF**



Kirby Chambliss Aerobatics (Red Bull) - Emergency Extraction Document Generated: June 9, 2023, 3:25 pm

# Emergency Extraction Information for Aircraft N423KC



Aircraft Type: Zivco Edge 540  
Registration: N423KC  
Pilot Name: Kirby Chambliss  
Emergency Contact Name: Kellie Chambliss  
Emergency Contact Number: 602-721-3093  
Date: 7/23/14

# Electrical/Ignition System N423KC



# Harnesses N423KC



Aircraft Type: Zivco Edge 540  
Registration: N423KC  
Pilot Name: Kirby Chambliss  
Emergency Contact Name: Kellie Chambliss  
Emergency Contact Number: 602-721-3093  
Date: 7/23/14

**Ejection System  
N423KC**

**N/A**

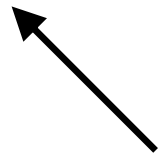

**Hazmat  
N423KC**

**N/A**

Aircraft Type: Zivco Edge 540  
Registration: N423KC  
Pilot Name: Kirby Chambliss  
Emergency Contact Name: Kellie Chambliss  
Emergency Contact Number: 602-721-3093  
Date: 7/23/14

## Fuel System N423KC



## Canopy System N423KC



Aircraft Type: Zivco Edge 540  
Registration: N423KC  
Pilot Name: Kirby Chambliss  
Emergency Contact Name: Kellie Chambliss  
Emergency Contact Number: 602-721-3093  
Date: 7/23/14



# Emergency Extraction Information for Aircraft N423KC



Aircraft Type: Zivco Edge 540  
Registration: N423KC  
Pilot Name: Kirby Chambliss  
Emergency Contact Name: Kellie Chambliss  
Emergency Contact Number: 602-721-3093  
Date: 7/23/14

# Electrical/Ignition System N423KC



# Harnesses N423KC



Aircraft Type: Zivco Edge 540  
Registration: N423KC  
Pilot Name: Kirby Chambliss  
Emergency Contact Name: Kellie Chambliss  
Emergency Contact Number: 602-721-3093  
Date: 7/23/14

**Ejection System  
N423KC**

**N/A**

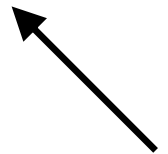

**Hazmat  
N423KC**

**N/A**

Aircraft Type: Zivco Edge 540  
Registration: N423KC  
Pilot Name: Kirby Chambliss  
Emergency Contact Name: Kellie Chambliss  
Emergency Contact Number: 602-721-3093  
Date: 7/23/14

## Fuel System N423KC



## Canopy System N423KC



Aircraft Type: Zivco Edge 540  
Registration: N423KC  
Pilot Name: Kirby Chambliss  
Emergency Contact Name: Kellie Chambliss  
Emergency Contact Number: 602-721-3093  
Date: 7/23/14

## Emergency Extraction Information for Aircraft N154EH and N133EH



Aircraft Type: MBB BO-105  
Registration: N154EH and N133EH  
Pilot Name: Aaron Fitzgerald  
Emergency Contact Name: Stan Gray  
Emergency Contact Number: 530-370-2748  
Date: 03/21/2018

## Electrical/Ignition System N154EH and N133EH

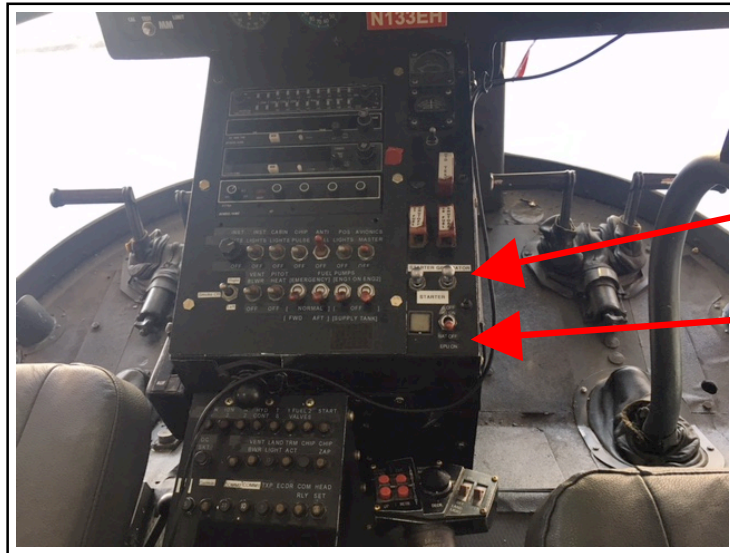

Starter/generator –  
middle = off

Master Switch – down  
= off.

## Harnesses N154EH and N133EH

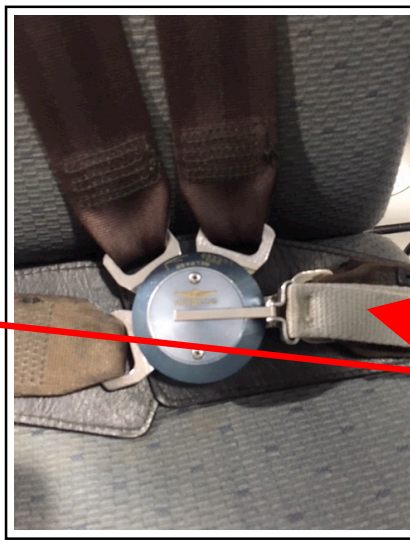

Lift grey  
webbing and  
release tabs

Aircraft Type: MBB B0-105  
Registration: N154EH and N133EH  
Pilot Name: Aaron Fitzgerald  
Emergency Contact Name: Stan Gray  
Emergency Contact Number: 530-370-2748  
Date: 03/21/2018

**Ejection System  
N154EH and N133EH**

N/A

**Hazmat  
N154EH and N133EH**

N/A

Aircraft Type: MBB BO-105  
Registration: N154EH and N133EH  
Pilot Name: Aaron Fitzgerald  
Emergency Contact Name: Stan Gray  
Emergency Contact Number: 530-370-2748  
Date: 03/21/2018

## Fuel System N154EH and N133EH



Overhead throttle x2 – aft to first detent. Depress two inner safetys, then fully aft.

Inner safetys

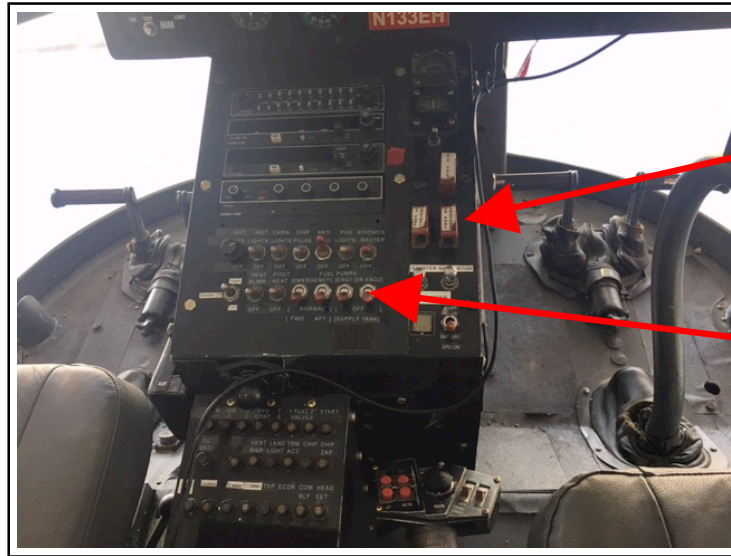

Emergency Fuel Shutoff x2 – Lift cover – switch down = off

Fuel Pump Switches x4 – down = off

## Canopy System N154EH and N133EH



Front door handle – swing down to open

Rear door handle – swing down to open



Front door opens up and forward.

Rear door – pull out and slide aft to open.

Aircraft Type: MBB B0-105  
 Registration: N154EH and N133EH  
 Pilot Name: Aaron Fitzgerald  
 Emergency Contact Name: Stan Gray  
 Emergency Contact Number: 530-370-2748





# Aircraft Safety

Blue Angels Weekend 2023

# Priorities in crash

- Discuss with your assigned crews the following scenarios:
  - Over Water
    - Pilot
    - Other Boats
    - Pier
  - Over Land
    - Pilot
    - Crowds
    - Buildings
    - Vehicles

# Blue Angel Emergencies

- Priorities
  - Ejection Seat
  - Throttle
  - Fuel
  - APU (Auxiliary Power Unit)
  - Battery
  - OxyComms (Mask attachment)

# Canopy Removal (if not jettisoned)

**Canopy Access (push button access)**

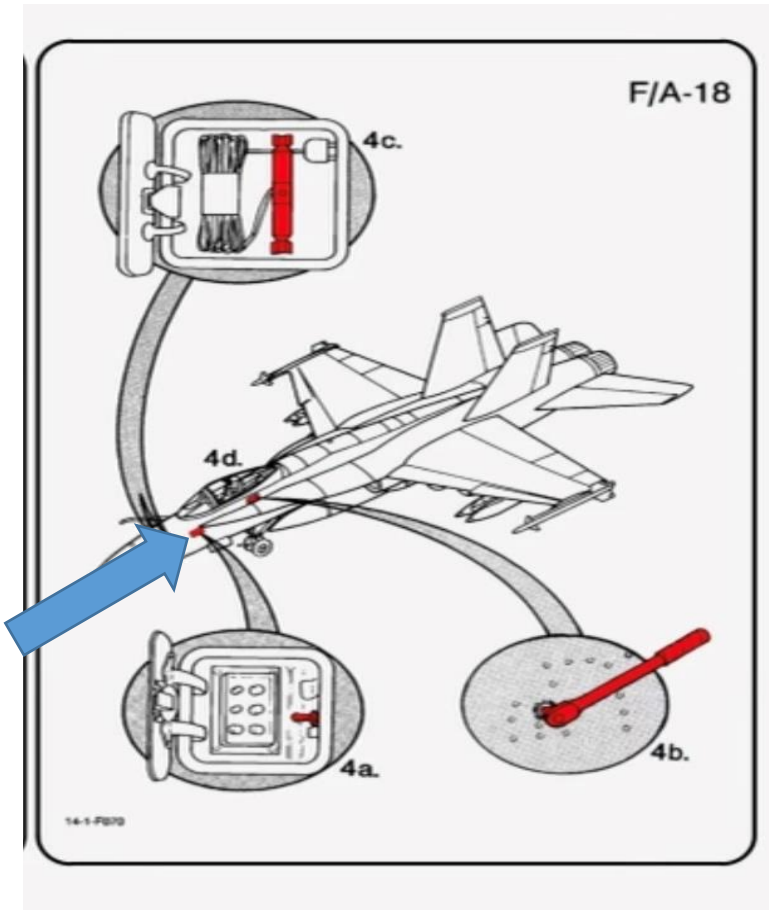

**Canopy Toggle Switch (Up for Up)**



# Ejection Seat Safe

**Located by  
Pilot Right Leg**



**Lift rocker switch on side to "SAFE" Position**

**\*Only white label facing up**



SEAT SAFE  
White Lapel On Top



Override  
Button to  
OFF Position

Throttle



# APU Shutoff Switch



Figure B-3. F/A-18 Hornet Crew Crew Information (Sheet 10)

**6. ENGINE/APU SHUTDOWN (NORMAL/EMERGENCY) (INTERNAL VIEW) (REF A)**

The engines may be shut down by using the throttles or fuel shutoff valve controls.

- a. N/A
- b. N/A
- c. N/A
- d. **THROTTLES**  
RAISE finger lifts and MOVE throttles fully AFT to OFF position.
- e. **FUEL SHUTOFF VALVE CONTROLS**  
Lift guard and PRESS the Left and Right FIRE warning lights. A time delay of approximately 30 seconds or less (with engines at MIL through IDLE) may be expected before engine shutdown occurs.  
**Note**  
On aircraft 160775 thru 160781 and F/A-18B aircraft BUNO 160782, valve levers are located AFT of throttles. PULL levers to FULL UP position.
- f. N/A
- g. **APU**  
Auxiliary Power Unit may be shut down by placing APU Switch in OFF position.

**WARNING**

Puddling of fuel under aircraft indicates presence of residual fuel in engine bay. With APU running, this can cause fire/explosion. Ensure APU shutdown prior to crewmember rescue.

F/A-18

14-14073



# Engine Extinguisher- after Engine Idled

- Left Engine Extinguisher



- Right Engine Extinguisher



# Pilot Harness System

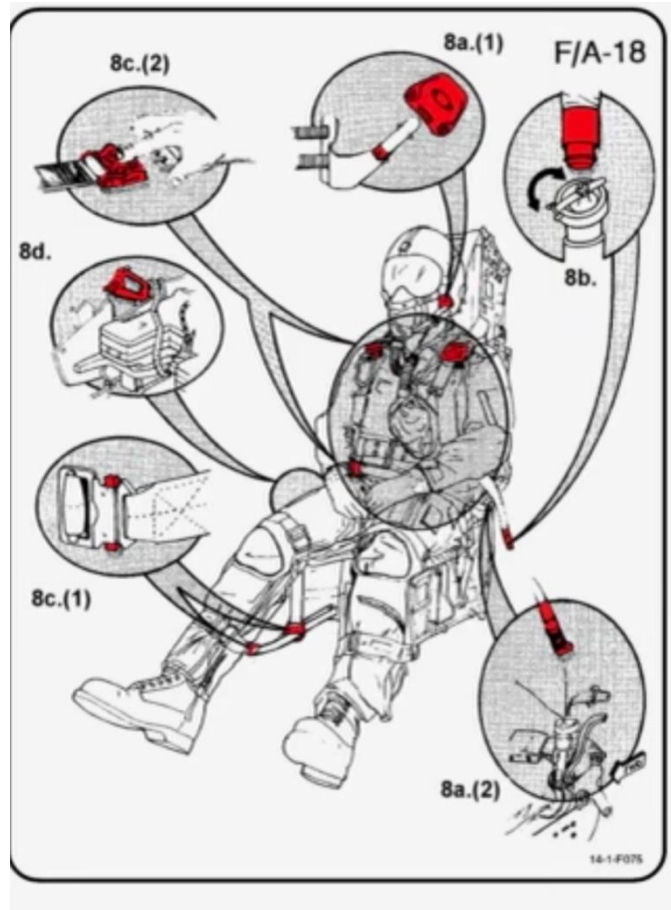

- Shoulder Straps
  - Buckle (No Cut)
- Lap Belt
  - Buckle (Can Cut)
- Leg Straps
  - Buckles (Can Cut)
- COMMS Link
  - Pneumatic pull-back collar ring

# Pilot Removal

- Shoulder Strap- Operate Buckle



- Waist Strap- Operate Buckle



# Pilot Removal

- Leg Straps- Cobra Buckle



- OXY/Comms- Pneumatic Collar



Batteries- Right Leg  
Toggle to "OFF"  
\*Note Seat Safe\*

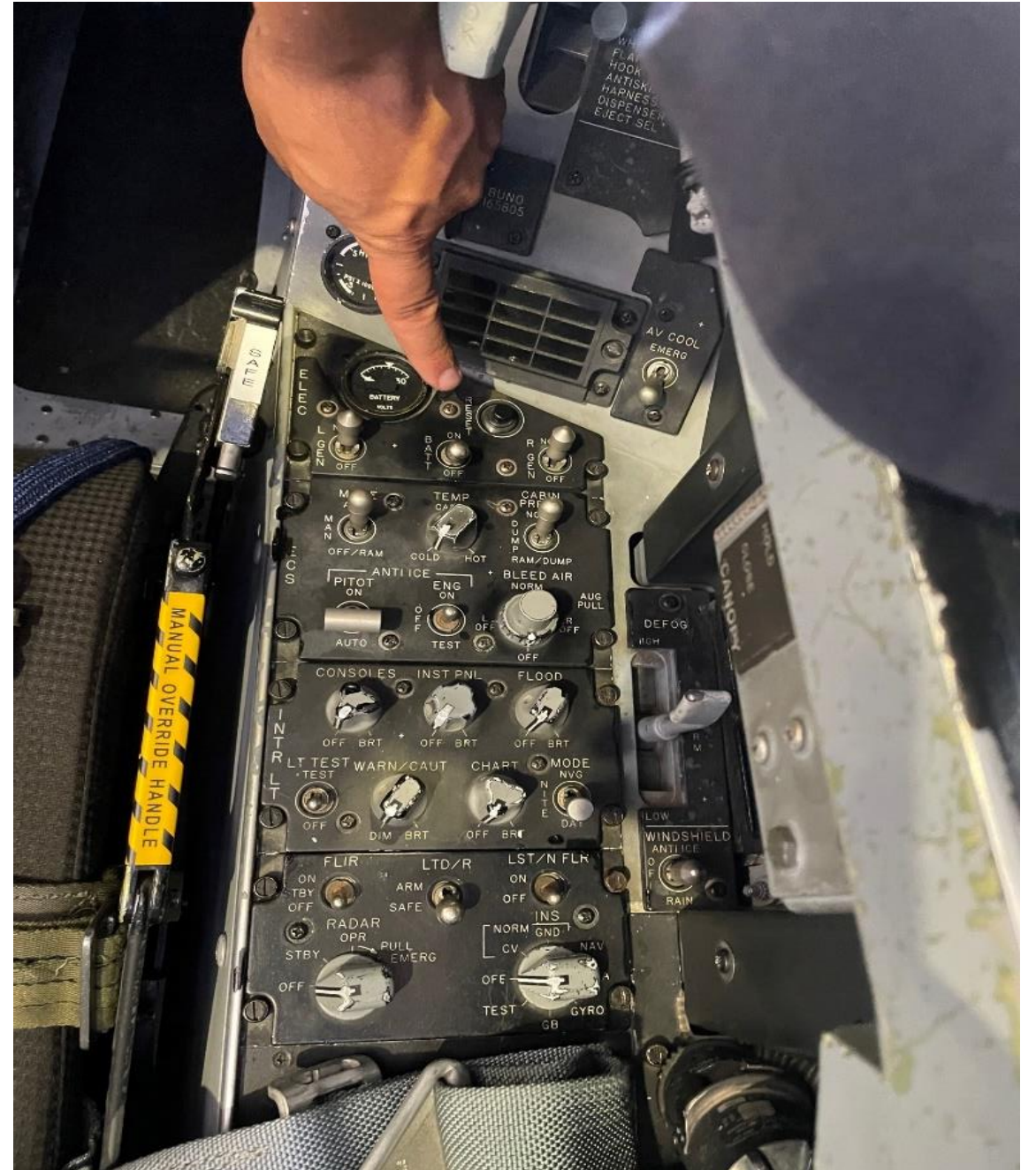

# Outside Dangers



- “Black Box” has rocket cover that will jettison on impact. Between tail fins.
- Do NOT work or stand over this area.
- Aircraft skin will be slick if wet, use the grip taped portions around the cockpit only
- If fire present, not enough agent onboard or with fire truck to extinguish. Save lives, then deluge.



**Adam Baker's Playful Airshows**  
Emergency Extraction Info for N330PB



Aircraft Type:Extra 300/c

Registration:N330PB

Pilot Name:Adam Baker

Emergency Contact #1:  
Katie Baker 406-690-8527  
Emergency Contact #2:  
Ryan Baker 405-593-7572

Briefing: If the Extra is landed off of the runway most likely the aircraft will flip over. In the case that the aircraft is flipped over it only takes 2 men to lift the tail while another gets the pilot out of the aircraft. (IF IM NOT OUT OF THE AIRPLANE SCREAMING DON'T FOAM ME, FOAM THE ENTIRE AIRCRAFT!!!!!!)



**Canopy System**  
TO OPEN

There is no external latch to open the canopy so you will open it from the inside

1. Spring loaded door can be pushed or forced in (push lightly on the back end)

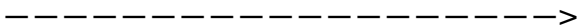

2. Slide the door back so the entire 5x7 window is open

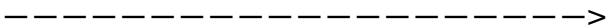

3. Grab both red handle and squeeze them together and lift canopy until it rests on the rope holding it open.

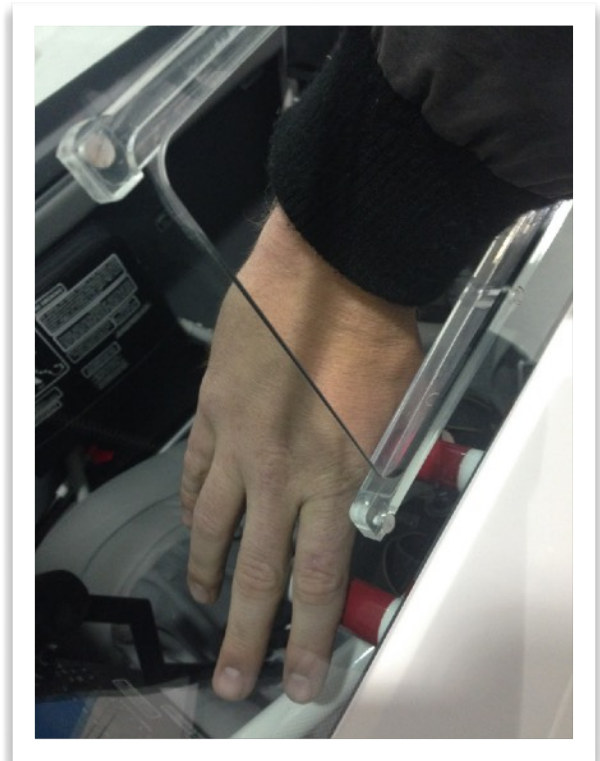

## Fuel

4. Find the fuel cut offs located in the cockpit.
1. Fuel Mixture knob is by the pilots left leg (use thumb to depress center and other fingers to pull knob towards the aft section of the aircraft).
  2. The selector valve is located by the pilots right leg (diagram is shown above)(down is off)

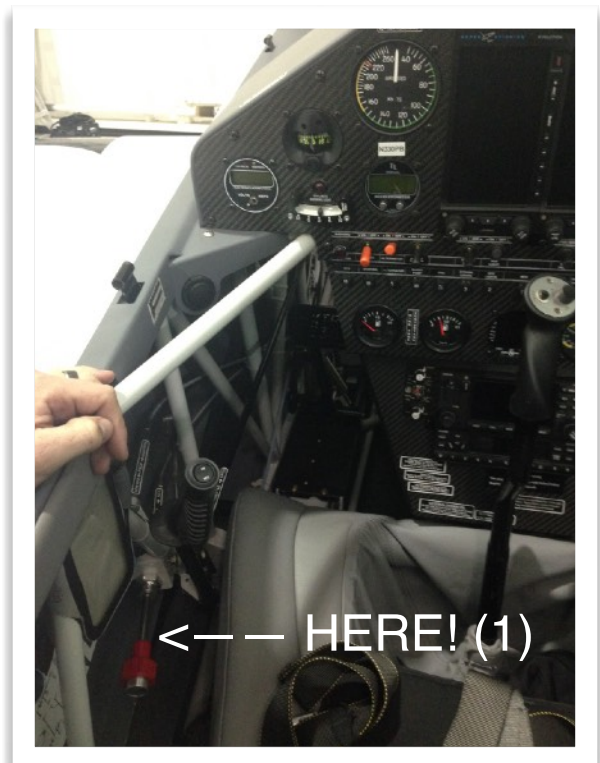
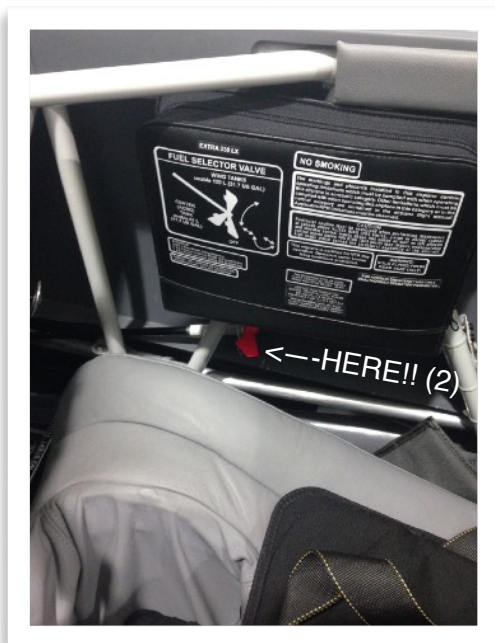



## Electrical

IF THE SWITCH IS ORANGE TURN IT OFF!!!!

1. There are two switches in the cockpit on the left side of the dash. Place both of those in the down position and all electrical is off.

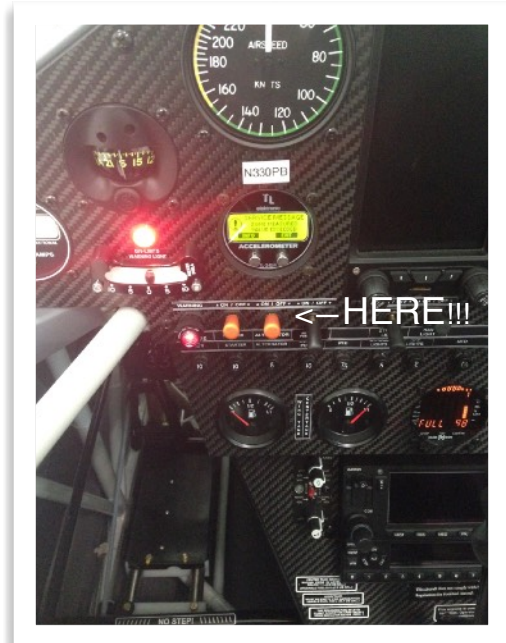
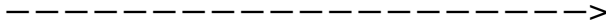

## Ignition

The ignition switch is located on the right side of the dash.

1. Turn the key all the way to the left and that is the off position. This will kill the ignition to the engine.

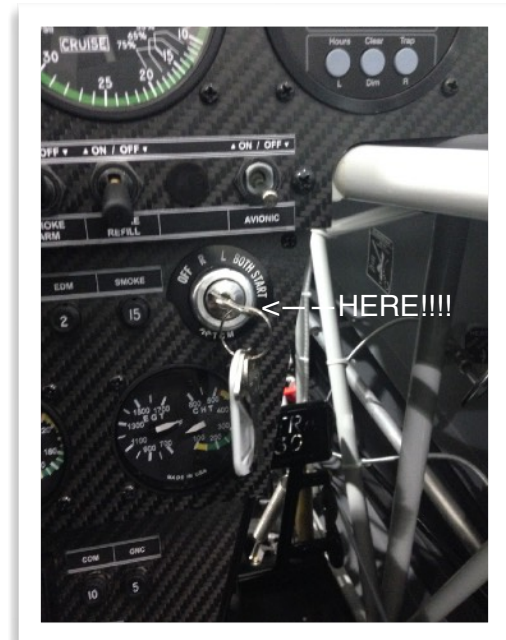

## Seat Belts

The pilot wears a standard 7 point racing harness. In the center are two levers to lift and the entire harness system comes free. (remove pilots headset before extracting)

## Hazmat

Forward of the front seat are the two tanks and a battery. —>

Gas on board 17 gallons,

Smoke oil on board 9 gallons.

## Pilot

The pilot is not allergic to any medicines.



# Emergency Extraction Information for Aircraft N60198



## Harness – N60198

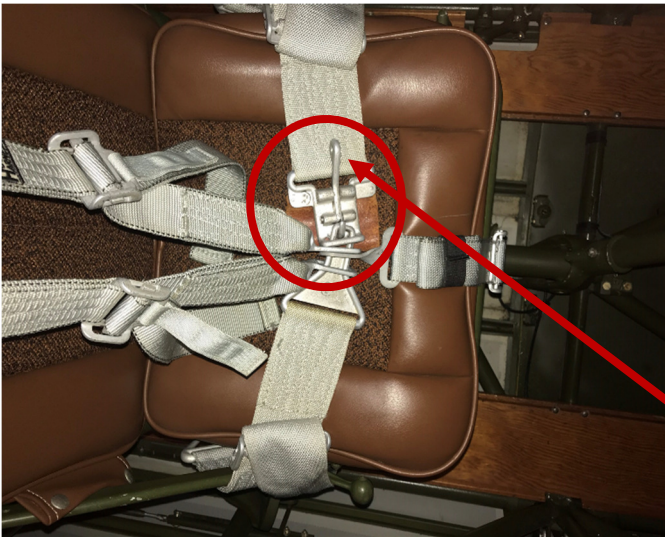

Both cockpits have a 5 point harness system that uses two lap belts, two shoulder straps and a crotch strap.

The entire system can be quickly released by lifting the single lever circled in the photo. It is not necessary to loosen any of the straps prior to release.

**PULL UP OR LIFT HANDLE  
TO RELEASE HARNESS**

Aircraft Type:	Boeing A75N1 (Stearman)
Registration:	Roy M. Kinsey, Jr.
Pilot Name:	Roy M. Kinsey, Jr.
Emergency Contact Name:	Pat Kinsey
Emergency Contact Number:	850-982-8167
Date:	22 March 2019

## Electrical/Ignition Systems - N60198



The electrical master switch is the inboard switch on the top row of the avionics panel that is mounted on the starboard side of the aft cockpit.



A magneto switch is located on the lower left corner of the instrument panel in both the aft and forward cockpits. Ignition is switched off by rotating either switch counter clockwise.

## Fuel System - N60198

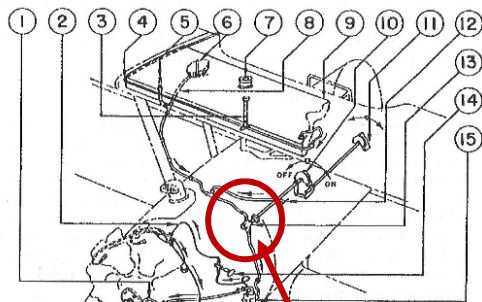

NOTE:

LEFT HAND SIDE OF FUEL TANK IDENTICAL WITH RIGHT HAND SIDE

- |                          |                                      |
|--------------------------|--------------------------------------|
| 1. CARBURETOR            | 9. FUEL TANK-46 GALS.                |
| 2. PRIMER LINE TO ENGINE | 10. FUEL VALVE CONTROL FRONT COCKPIT |
| 3. FUEL GAGE             | 11. FUEL VALVE CONTROL REAR COCKPIT  |
| 4. VENT LINE             | 12. LINE FROM LEFT OUTLET & SUMP     |
| 5. OUTLET LINE           | 13. FUEL VALVE                       |
| 6. SUMP                  | 14. PRIMER                           |
| 7. FILLER NECK           | 15. FUEL STRAINER                    |
| 8. FUEL LINE FROM TANK   |                                      |

REFERENCE DRAWING A75N3100

FIG.8 FUEL SYSTEM DIAGRAM MODEL N2S-4



All fuel is contained in a 46 gallon tank located in the center section of the upper wing. Fuel is gravity feed to the engine through a fuel shut off valve mounted on the aft side of the firewall.

Fuel valve shut off controls are mounted below the left side of the instrument panels in both the forward and aft cockpits. Turning the red control lever in either cockpit clockwise (right) turns off fuel to the engine.

### **Canopy System - N60198**

**Airplane is NOT equipped with a canopy.**

### **Ejection System - N60198**

**Airplane is NOT equipped with an ejection system.**

### **Hazmat - N60198**

**Airplane does NOT carry any hazmat, oxygen or hydrazine.**

Aircraft Type:	Boeing A75N1 (Stearman)
Registration:	Roy M. Kinsey, Jr.
Pilot Name:	Roy M. Kinsey, Jr.
Emergency Contact Name:	Pat Kinsey
Emergency Contact Number:	850-982-8167
Date:	22 March 2019

# Emergency Extraction Information for Kevin Coleman



Aircraft Type: Extra 300  
Registration: 821EX  
Pilot Name: Kevin Coleman  
Emergency Contact Name: Wyche Coleman  
Emergency Contact Number: 318-218-7644  
Date: 7-24-2014

## Electrical/Ignition System N821EX



Red switch is  
**MASTER**  
Down = OFF

## Harnesses N821EX



Aircraft Type: Extra 300  
Registration: 821EX  
Pilot Name: Kevin Coleman  
Emergency Contact Name: Wyche Coleman  
Emergency Contact Number: 318-218-7644  
Date: 7-24-2014

## Fuel System N821EX

Down = OFF

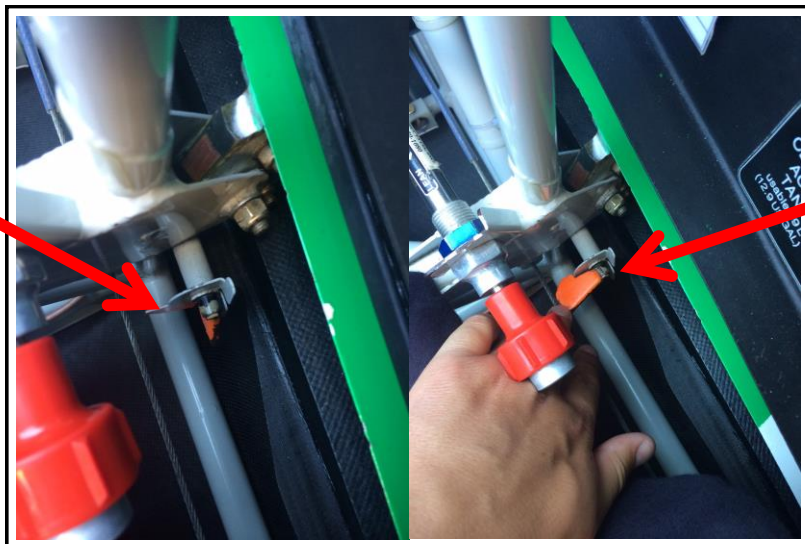

Up = ON

## Canopy System N821EX



Aircraft Type: Extra 300  
Registration: 821EX  
Pilot Name: Kevin Coleman  
Emergency Contact Name: Wyche Coleman  
Emergency Contact Number: 318-218-7644  
Date: 7-24-2014



# Emergency Extraction Information Pitts “Prometheus” N540S and N540SS



Pilot: William Lewis “Skip” Stewart 901-355-4100  
Emergency Contact: Cari Miller 954-789-3205

## General Aircraft Information

The aircraft is constructed of wooden wings and a steel tubular fuselage. The entire aircraft is covered with fabric, with the exception of the fuselage areas from the cockpit forward, which are covered with aluminum panels. There are four fuel tanks located forward of the pilot inside the fuselage. The forward two tanks typically have smoke oil in them, and the aft two have 100LL Aviation Fuel. The battery is located behind the pilot seat and in an emergency can be accessed by cutting the fabric on the side of the fuselage, just aft of the cockpit. If the aircraft is inverted, it can typically be rotated to an upright position by having two or more people lift on the tail. The canopy has two latches, one on each side. They are small metal tabs that need to be lifted simultaneously, while sliding aft. There are also two thin metal straps that may need to be cut with a knife. The canopy is very fragile and can be ripped off by grabbing the aft section and pulling forward, or by hitting it with a crash axe or hammer. The seatbelt is a typical "Hooker" harness with two lap belts. Each belt has a lever in the center that can be disconnected easily by lifting the lever up. One these two levers are raised, the entire belt system will release, allowing for removal of the pilot. The best way to extract the pilot is to pull on the parachute shoulder straps.

## Battery Location

The battery is located on this tray behind the pilot seat



# Fuel System

Four tanks forward of the pilot

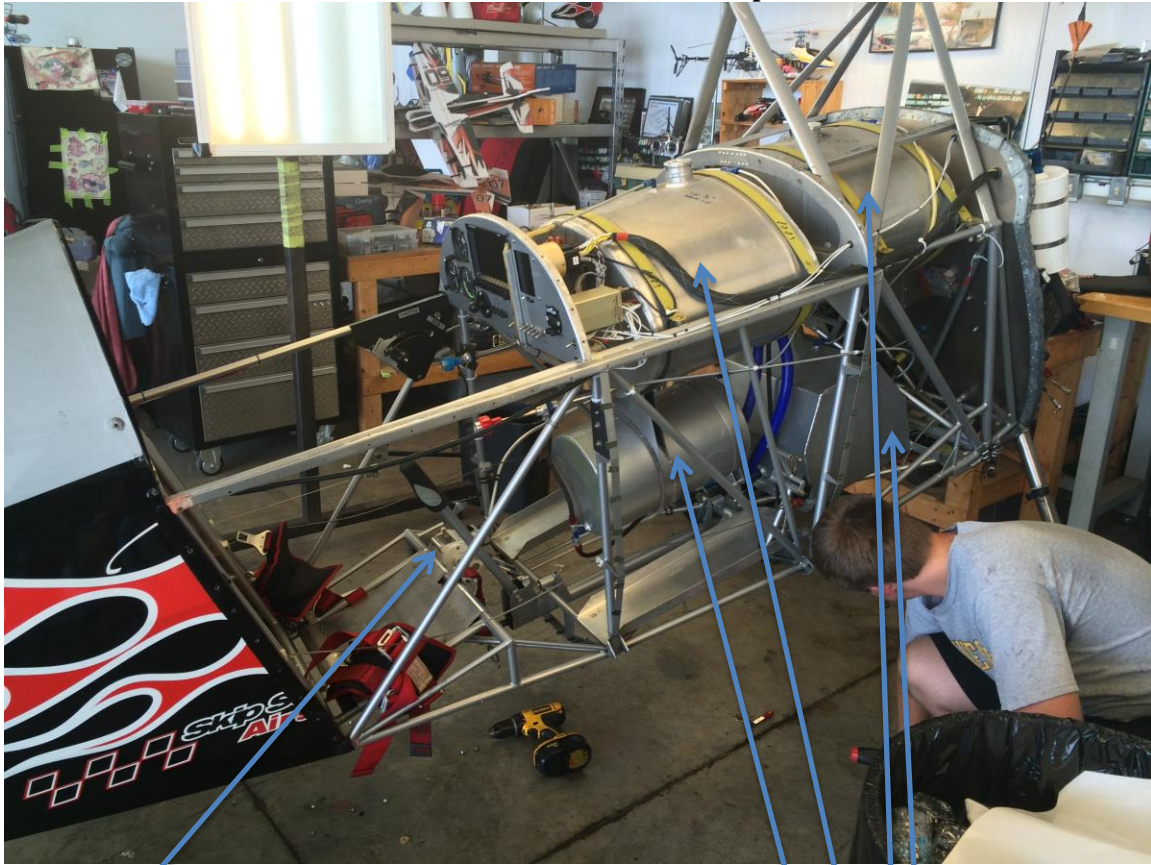

Fuel Selector and shut-off

Fuel Tanks

## Canopy



Grab here and pull in emergency

Lift metal tabs on each side to slide.

Thin metal straps that may need to be cut.

## Seatbelts



### Harness Release

The pilot's harness is released by unlatching two lap belts. Rotate the locking bar on each lap belt, then clear away the straps.

*If time is critical, cut all required straps to remove pilot.*

*Pull to rotate the two locking bars*

# Emergency Extraction Information for Aircraft N803RL



Aircraft Type: Van's RV8  
Registration: N803RL  
Pilot Name: Ken Rieder  
Emergency Contact Name: Christy Rieder  
Emergency Contact Number: 513-404-2166  
Date: Mar -21 -2019

## Electrical/Ignition System N803RL



## Harnesses N803RL



A  
R  
P  
E

Emergency Contact Number: 513-404-2166  
Date: March – 21 - 2019



**Ejection System  
N803RL**

NONE

**Hazmat  
N803RL**

None

Aircraft Type: Van's RV8  
Registration: N803RL  
Pilot Name: Ken Rieder  
Emergency Contact Name: Christy Rieder  
Emergency Contact Number: 513-404-2166  
Date: March - 21 - 2019

## Fuel System N803RL



## Canopy System N



Aircraft Type: Van's RV8  
Registration: N803RL  
Pilot Name: Ken Rieder  
Emergency Contact Name: Christy Rieder  
Emergency Contact Number: 513-404-2166  
Date: March - 21 - 2019





SCHEDULE FOR  
**PENSACOLA BEACH, FL**  
**PENSACOLA BEACH AIRSHOW**  
**8 JULY 2023**

**AIR SHOW POINTS OF CONTACT:**

AIR SHOW COORDINATOR: Robbie Schrock PHONE: N/A CELL: (850) 485-7589 EMAIL: robbie_schrock@sria-fla.com	FAA MONITOR: John Vaughan PHONE: N/A CELL: (205) 306-3968 EMAIL: john.vaughan@faa.gov
BLUE ANGEL LIAISON: Robbie Schrock PHONE: N/A CELL: (850) 485-7589 EMAIL: robbie_schrock@sria-fla.com	POLICE POC: Chief Richard Hawthorne PHONE: (850) 934-5121 CELL: (850) 232-9714 EMAIL: rhawthorne@gulfbreeze.fl.gov
MAINTENANCE POC: Kirk Troil PHONE: (850) 595-4719 CELL: (850) 281-9919 EMAIL: kptroil@myescambia.com	USN RECRUITER POC: N/A PHONE: N/A CELL: N/A EMAIL: N/A
PUBLICITY POC: Katie King PHONE: (850) 438-4015 CELL: (850) 723-6737 EMAIL: katie@ewbullock.com	USMC RECRUITER POC: N/A PHONE: N/A CELL: N/A EMAIL: N/A
SECURITY POC: James Barnes PHONE: (850) 932-9211 CELL: (850) 786-7097 EMAIL: jrbarnes@escambiaso.com	MEDICAL POC: Dave Greenwood PHONE: (850) 916-5232 CELL: (850) 554-4302 EMAIL: degreenwood@myescambia.com

<b>Start:</b> 1100 <b>BA Start:</b> 1400 <b>Sunset:</b> 1954
<b>Air Boss:</b> Paul Entrekin <b>Announcer:</b> Rob Williams
<b>Air Show Performers:</b> Kevin Coleman, Aaron Fitzgerald and Red Bull Air Force Jump Team, Veterans Flight, Bill Culberson, Redline, Skip Stewart

**SHOWSITE SPECIFICS**

**Brief Room:** Blue Angels Ready Room, 390 San Carlos Rd. Suite A, Pensacola, FL 32508  
 Phone: N/A

**Make-a-Wish POC:** N/A  
 Kids/Total: N/A  
 Cell: N/A

**SUNDAY, 2 JULY 2023 (Partly Cloudy, H: 93°, L: 78°)**  
 2030 Skeds/AOM

**MONDAY, 3 JULY 2023 (Partly Cloudy, H: 90°, L: 79°)**  
 0730 FA-18 Pilot Finalists – Pilot Strength Test #1 at NASC Track  
 0730 All other finalists – Navy Psychology Interviews, Pilot shop  
 0800 Finalists uniform measurements in Supply Office  
 1000 #7 meets with Pensacola Beach committee in Santa Rosa Island Authority  
 1300 FA-18 Pilot Finalists – Navy Psychology Interviews, Pilot shop  
 1800 Finalists’ dinner with 2024 team at The Fish House, 600 S Barracks St., Pensacola, FL 32502 (\$40/person)

**TUESDAY, 4 JULY 2023 (Scattered Thunderstorms, H: 91°, L: 78°)**  
 0530 Commence finalists’ interviews in Ready Room (Uniform – Khakis / Charlies) [1<sup>st</sup> Interview: 0600]  
 0545 Meet with Navy Psychologists in Ready Room  
 0545 Finalists arrive at squadron spaces and check-in with #2  
 0900 Finalists photos in front of jet in hangar  
 1055 Depart for finalists’ lunch at Cubi Point Bar, National Naval Aviation Museum (West Pac Room) (\$15/person) [Lunch: 1100]  
 1150 Resume finalist interviews  
 1800 Finalists dinner with 2023 team and spouses at Angelena’s Ristorante Italiano, 101 E. Intendencia St., Pensacola, FL 32502 (\$72/person)

**WEDNESDAY, 5 JULY 2023 (Scattered Thunderstorms, H: 91°, L: 77°)** (Airspace Waiver: 0730 – 1100) (TFR: 0730 – 1100)  
 0600 Finalists arrive at squadron spaces and complete Supply, Public Affairs, and Admin processing  
 0615 XO, MO, AMO, and Comm Cart personnel depart for Pensacola Beach (**Tan Polos / Blue Shorts**)  
 0625 Brief circles (with finalists)  
 0700 FA-18 Pilot Finalists – Pilot Strength Test #2 at Radford Gym  
 0700 #7 and #8 meet USCG helicopter pilot at NASP transient line POC: LT Rhea Phone: (903) 316-0170  
 0705 #7 and #8 depart NASP transient line for Pensacola Beach via USCG helicopter (on deck 0725)  
 0710 #1 – #4 walkdown for Pensacola Beach, FL circle maneuvers [OVHD: 0730]  
 0725 #7 and #8 return NASP transient line via USCG helicopter  
 0800 Breakfast with the Blues outreach – All interested at 3<sup>rd</sup> Floor Casino Beach Bar, 41 Ft. Pickens Rd., Pensacola Beach, FL  
 0810 #5 and #6 walkdown for Pensacola Beach, FL circle maneuvers [OVHD: 0830] [#5 Ride: #7]  
 0900 Diamond debrief circles (with finalists)  
 0925 Fat Albert launches for Pensacola Beach, FL circle maneuvers [OVHD: 0930]  
 1000 XO, MO, AMO, and Comm Cart personnel depart Pensacola Beach for airfield  
 1400 Beach Day with finalists at Casino Beach Bar and Grille; 41 Fort Pickens Rd., Gulf Breeze, FL 32561

**THURSDAY, 6 JULY 2023 (Scattered Thunderstorms, H: 90°, L: 76°)****(Airspace Waiver: 1300 – 1530) (TFR: 1300 – 1530)**

0800 7CC brief Key Influencer and Media Rider in Public Affairs  
 0900 #7 walkdown for Key Influencer Dr. Kimberly Thomas and Media Rider Mel McCrae flights (2) [0915, 1030]  
 1000 DH meeting  
 1120 [Boss], [#4, AZ2 Phibbs], [#5, PS1 Alvarez] and MC1 Deccio media availability in front of jets (1120 – 1140)  
 1220 #7, #8, XO, MO, AMO, DOC, SUPPO, and Comm Cart personnel depart for Coast Guard station (**Blue Polos / Tan Shorts**)  
 1230 #7, #8, XO, MO, AMO, DOC, SUPPO, and Comm Cart personnel depart Coast Guard station via boat for Peg Leg Pete's  
 1250 Brief  
 1310 #7, #8, XO, MO, AMO, DOC, SUPPO, and Comm Cart personnel depart Peg Leg Pete's for Pensacola Beach with police escort  
 1350 #1 – #6 walkdown for Pensacola Beach, FL practice flight demonstration [#4 Ride: LT Larissa Brandenburg]  
 1355 Fat Albert launches for Pensacola Beach, FL practice flight demonstration with approved riders [OVHD: 1400]  
 1355 LCDR Rickoff launches for Pensacola Beach Photo Platform with MC2 Cardona  
 1515 #7, #8, XO, MO, AMO, DOC, SUPPO, and Comm Cart personnel depart beach for Peg Leg Pete's with escort, then via boat to Coast Guard station  
 1615 Debrief  
 1730 Pick 2024 Blue Angel Officer Team Members

**FRIDAY, 7 JULY 2023 (Scattered Thunderstorms, H: 89°, L: 77°)****(Airspace Waiver: 1100 – 1700) (TFR: 1200 – 1600)**

0800 #8 Performers brief (VTC) POC: Robbie Schrock Phone: (850) 485-7589  
 1220 #7, #8, XO, Mini-XO, MO, DOC, and Comm Cart personnel depart for Coast Guard station (**Tan Polos/ Blue Shorts**)  
 1230 #7, #8, XO, Mini-XO, MO, DOC, and Comm Cart personnel depart Coast Guard station via boat for Peg Leg Pete's  
 1250 Brief  
 1310 #7, #8, XO, Mini-XO, MO, DOC, and Comm Cart personnel depart Peg Leg Pete's for Pensacola Beach with police escort  
 1350 #1 – #6 walkdown for Pensacola Beach, FL practice flight demonstration [OVHD: 1410] [#4 Ride: SUPPO]  
 1355 Fat Albert launches for Pensacola Beach, FL practice flight demonstration [OVHD: 1400]  
 1355 LCDR Rickoff launches for Pensacola Beach Photo Platform with MC2 Cardona (backup)  
 1515 #7, #8, XO, Mini-XO, MO, DOC, and Comm Cart personnel depart beach for Peg Leg Pete's with escort, then via boat to Coast Guard station  
 1615 Debrief

1900

**MANDATORY OFFICERS AND ENLISTED: Blue Angels Reception**

Scheduled: 1930-2130 (1900-1930: Reserved for BA & Spouses)  
 Address: Hilton Pensacola Beach Gulf Front  
 12 Via de Luna, Pensacola Beach, FL 32561  
 Attire: Show Suits  
 Food: Hosted  
 Drinks: Hosted  
 Introductions: Yes  
 Presentations: Yes  
 Total Att: 550  
 Guest: Yes  
 Guest Attire: Business Casual

Host: Santa Rosa Island Authority  
 POC: Robbie Schrock  
 Phone: (850) 485-7589  
 Email: Robbie\_Schrock@sria-fla.com  
 Fundraiser for Host: No  
 Team Cost: None  
 Team Participation: None  
 Food/Drink Value: \$30.00  
 Cost of event for all attendees: \$20,000.00  
 Attendees: Community members, beach business owners, elected officials

**SATURDAY, 8 JULY 2023 (Scattered Thunderstorms, H: 89°, L: 78°)****(Airspace Waiver: 1100 – 1700) (TFR: 1200 – 1600)**

0800 XO Performers brief at Santa Rosa Island Authority, 1 Via de Luna Pensacola Beach, FL 32561  
 1000 All Officers arrive squadron spaces for finalist call-ins  
 1015 Finalist call-ins begin  
 1150 Finalist call-ins end  
 1220 #7, #8, Mini-XO, MO, AMO, DOC, SUPPO, and Comm Cart personnel depart for Coast Guard station (**Blue Polos / Tan Shorts**)  
 1230 #7, #8, Mini-XO, MO, AMO, DOC, SUPPO, and Comm Cart personnel depart Coast Guard station via boat for Peg Leg Pete's  
 1250 Brief  
 1310 #7, #8, Mini-XO, MO, AMO, DOC, SUPPO, and Comm Cart personnel depart Peg Leg Pete's for Pensacola Beach with police escort  
 1350 #1 – #6 walkdown for Pensacola Beach, FL flight demonstration [OVHD: 1410] **(30)**  
 1355 Fat Albert launches for Pensacola Beach, FL flight demonstration [OVHD: 1400]  
 1515 #7, #8, Mini-XO, MO, AMO, DOC, SUPPO, and Comm Cart personnel depart for Peg Leg Pete's with escort, then via boat to Coast Guard station  
 1615 Debrief

**SUNDAY, 9 JULY 2022 (Scattered Thunderstorms, H: 90°, L: 79°)****(Airspace Waiver: 1100 – 1700) (TFR: 1200 – 1600)****WEATHER BACK-UP DAY / NO FLIGHTS SCHEDULED / DAY OFF**

# MARINE ZONES

Marine Zones for Blue Angels Air Show July 2023

## Legend

- ZONE 1
- ZONE 2
- ZONE 3
- ZONE 4
- ZONE 5
- ZONE 6

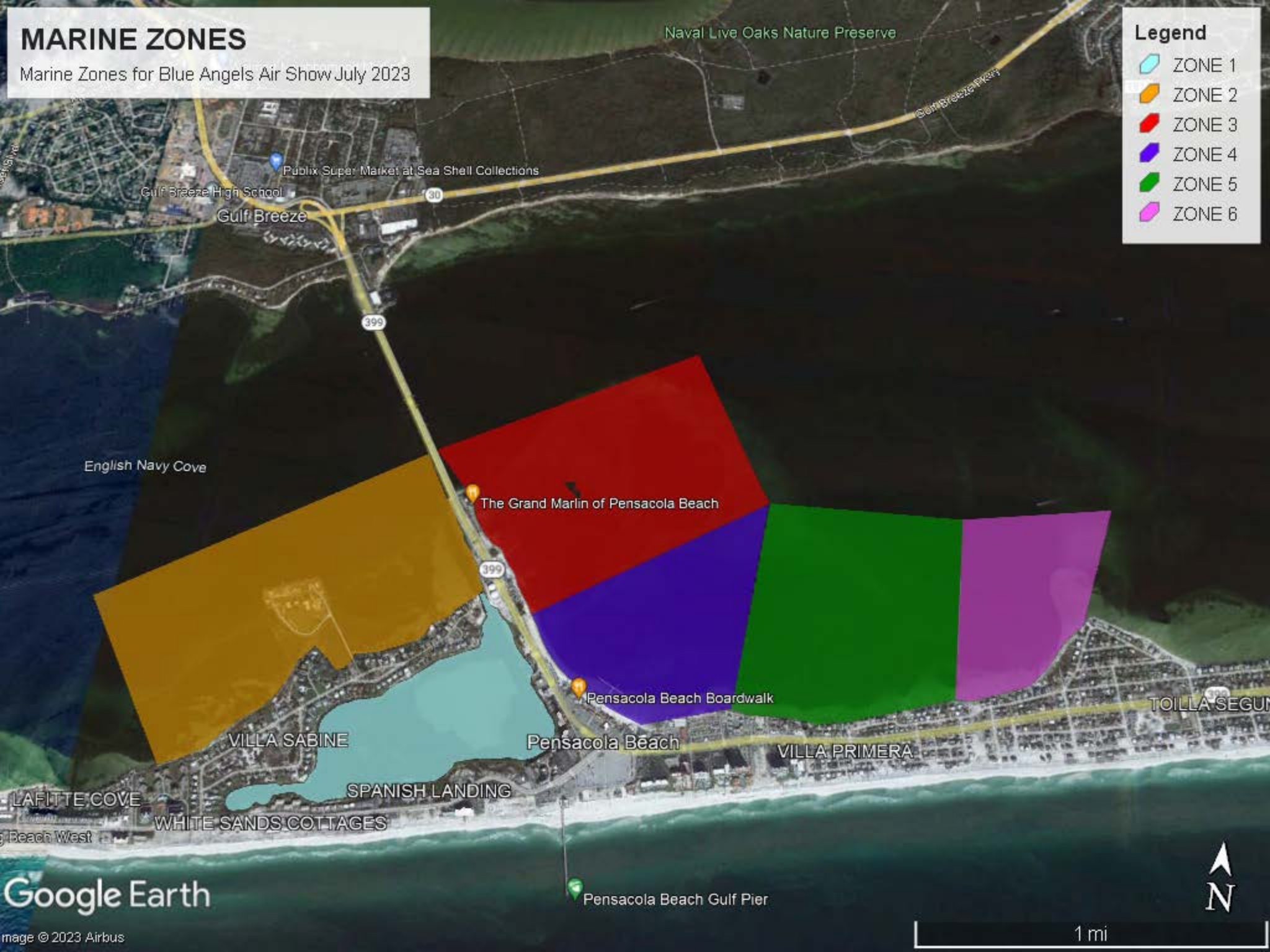

English Navy Cove

Naval Live Oaks Nature Preserve

Gulf Breeze Pkwy

Gulf Breeze High School

Publix Super Market at Sea Shell Collections

Gulf Breeze

30

99

The Grand Marlin of Pensacola Beach

99

Pensacola Beach Boardwalk

TOILLA SEGUIN

VILLA SABINE

Pensacola Beach

VILLA PRIMERA

LAFITTE COVE

SPANISH LANDING

WHITE SANDS COTTAGES

Pensacola Beach Gulf Pier

Google Earth

Image © 2023 Airbus

1 mi

